

REV	DATE	DESCRIPTION	ECO	BY	C'H'K.
C	12/11/2008 12:00:00 AM	REDRAW AND CATALOG NUMBER UPDATION	16630	MA	BSK

CATALOG. NO.	CONDUCTOR		BOLT SIZE	FIG. NO.	DIMENSIONS								INSTALLATION TOOLING (# CRIMPS)														
	CODE (AWG)	NAVY			B	C	H REF.	K DIA.	L	N	O.D.	T REF.	Z MIN.	DIE INDEX	COLOR CODE	MECHANICAL					HYDRAULIC					DIELESS (# CRIMPS)	WIRE STRIP LENGTH
																MD7-34R	BCT500 Y500CT	Y34A	Y750 Y35, BAT35 Y39, BAT750	Y46	Y45	Y48B	Y60B				
D YAZ34TC38	500 kcmil [240mm ² STR.]	--	3/8 [M10]	1	2.25	1.55	--	.40	3.84	.41	1.06	.23	.42	20 OR 299	BROWN	W34RT	W34RT	A34R	U34RT	U34RT	U34RT	C34R	L34RT	HYDRAULIC Y644, Y644M BAT644M Y644MBH, Y1000 Y1000BH (1)	2-5/16		
YAZ34TC3845					2	2.94	3.49		1.53							U31ART	U31ART	U31ART	C31AR								
YAZ34TC3890					3	3.41	1.53																				
YAZ34TC12					1	--	4.10																				
YAZ34TC1245					1/2 [M12]	2	2.94		3.74							.53	20 OR 299	BROWN	W34RT	W34RT	A34R	U34RT	U31ART			U31ART	U31ART
YAZ34TC1290	500 kcmil [240mm ² STR.]	--		3	2.25	1.55	3.41	1.78	1.06	.23	.55	20 OR 299	BROWN	W34RT	W34RT	A34R	U31ART	U31ART	U31ART	C31AR	L34RT		2-5/16				

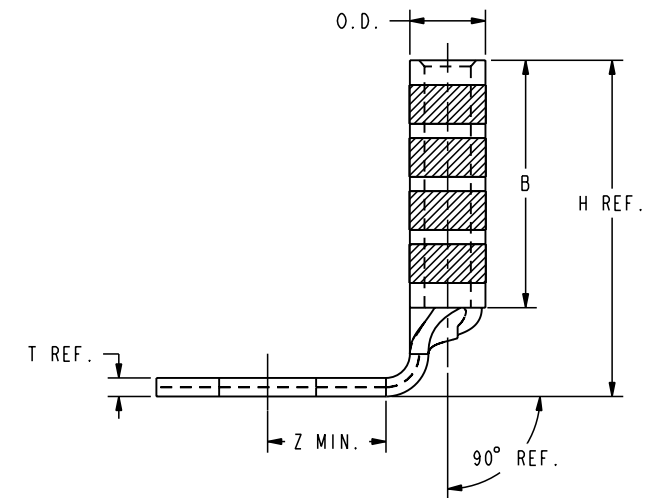
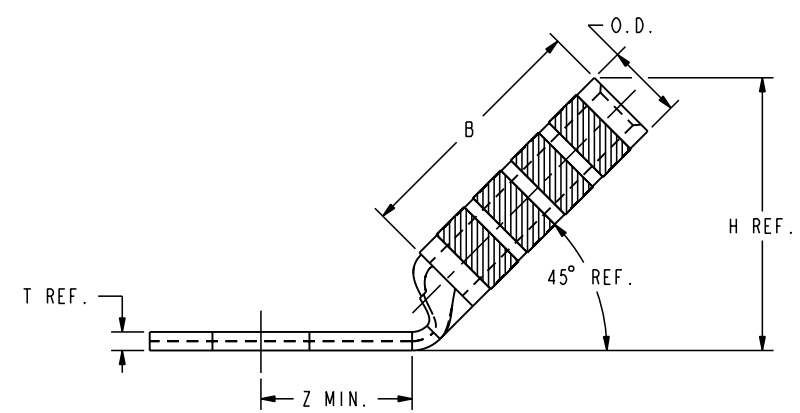
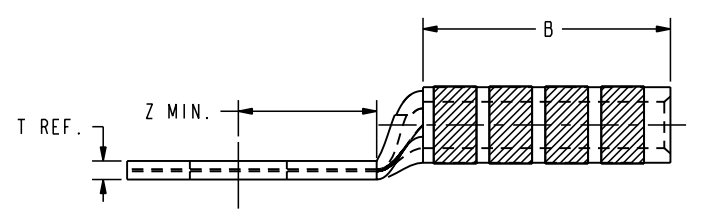
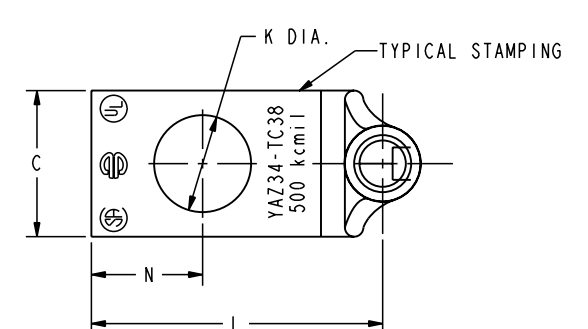
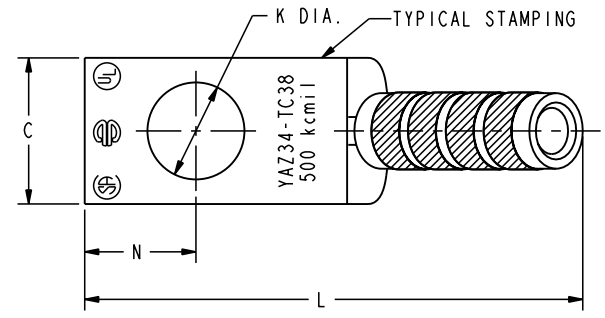
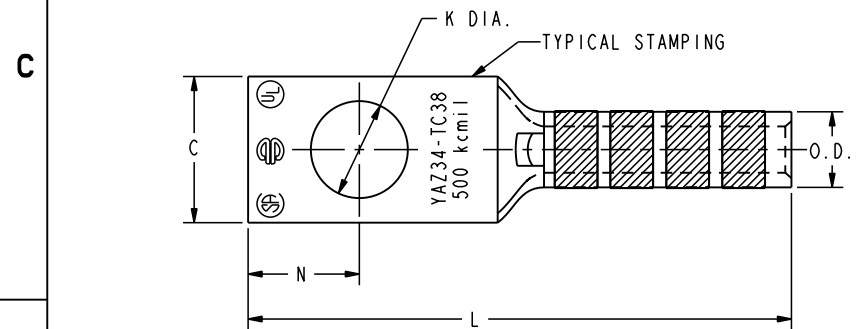

NOTES:

- MATERIAL: COPPER TUBING.
- FINISH: TIN PLATED
- CATALOG # PT6515 ADAPTOR IS REQUIRED TO USE "U" DIES IN Y45 SERIES TOOLS.
- CATALOG # PUADP-1 ADAPTOR IS REQUIRED TO USE "U" DIES IN Y46 SERIES TOOLS.
- DIMENSIONS, METRIC WIRE, & METRIC BOLT SIZES IN BRACKETS [] ARE IN MILLIMETERS. DIMENSIONS ARE ROUNDED OFF TO THE NEAREST MILLIMETER, UNLESS OTHERWISE NOTED, AND ARE FOR REFERENCE ONLY.
- FOR USE BY CUSTOMERS THAT HAVE THIS HYPRESS™. NO NEW Y34A HYPRESS™ TOOLS ARE BEING PROCESSED.

TO ORDER BURNDY® PRODUCTS CALL		HYLUG™ (ONE HOLE CODE)	
UNITED STATES 1-800-346-4175 (LONDONDERRY, NH)		ITEM NO: NA	CAT. NO: YAZ34-TC- (TABLE)
CANADA: 1-800-361-6975 (QUEBEC) 1-800-387-6487 (ALL OTHER PROVINCES)		DRAWN BY: D. BOISVERT 02/03/2000	CHECKER: K. MCCARTHY 04/05/2000
FOR PRODUCT INFO: http://www.burndy.com		DSN APPVL: J. MICHAUD 05/04/2000	MFG APPVL: N/A
		QA APPVL: S. BROWN	MKT APPVL: --
		SCALE: NTS	
		PROJ #:	SIZE: D
		DOCUMENT TYPE: Sales	DRAWING NO: SE212356
		REL LEVEL: Released	SHEET 26 OF 40

REV: PE0200